



**Buddy, Inc.**

INDUSTRIAL MANIPULATORS  
TDA BUDDY® SYSTEMS



Kalamazoo, MI 49009

Telephone: (269) 349-8105  
FAX: (269) 349-5406

Address Quote To: \_\_\_\_\_

Today's Date: \_\_\_\_\_

Date Quote Required: \_\_\_\_\_

Company Name: \_\_\_\_\_ Customer Name: \_\_\_\_\_

Street Address: \_\_\_\_\_ Title: \_\_\_\_\_

City: \_\_\_\_\_ State: \_\_\_\_\_ Zip: \_\_\_\_\_

Phone: (\_\_\_\_) \_\_\_\_\_ Fax: (\_\_\_\_) \_\_\_\_\_ E-Mail: \_\_\_\_\_

Rep Name: \_\_\_\_\_ Phone: (\_\_\_\_) \_\_\_\_\_

Fax: (\_\_\_\_) \_\_\_\_\_ E-Mail: \_\_\_\_\_

Number of Units Required: \_\_\_\_\_ Date Units Required: \_\_\_\_\_

**APPLICATION INFORMATION**

**Description/Name of Part:** \_\_\_\_\_  
\_\_\_\_\_

Part Weight: \_\_\_\_\_ Part Dimensions: \_\_\_\_\_

Special Handling Consideration: Finish Protection \_\_\_\_\_ Yes \_\_\_\_\_ No

Squeeze or Grip Limitations: \_\_\_\_\_ Temperature: \_\_\_\_\_

**Sequence of Operation Description (Lift, Tilt, Turn, etc.)**

\_\_\_\_\_  
\_\_\_\_\_  
\_\_\_\_\_  
\_\_\_\_\_

Time/Duty Cycle – Maximum Handling Time Per Cycle \_\_\_\_\_ seconds/minutes

Expected Number of parts to be handled per hour \_\_\_\_\_ Hours Per Day \_\_\_\_\_ Days Per Week \_\_\_\_\_

Potential End Effector: Pneumatic Gripper \_\_\_\_\_ Vacuum \_\_\_\_\_ Magnetic \_\_\_\_\_ Other \_\_\_\_\_

Available Power: Volts \_\_\_\_\_ Phase \_\_\_\_\_ Hz \_\_\_\_\_ Available Air Pressure \_\_\_\_\_

**MOUNTING CONSIDERATIONS**

Fixed Floor \_\_\_\_\_ Fixed Overhead \_\_\_\_\_ Portable Baseplate \_\_\_\_\_

Overhead Rail \_\_\_\_\_ Floor Supported Overhead Rail \_\_\_\_\_

Rail Length \_\_\_\_\_ Bridge \_\_\_\_\_

Rail Style \_\_\_\_\_ Open \_\_\_\_\_ Enclosed \_\_\_\_\_ Tractor \_\_\_\_\_ Yes \_\_\_\_\_ No

**(\*\*PLEASE COMPLETE OTHER SIDE\*\*)**

# FLOOR MOUNT MANIPULATOR/ Fixed or portable

A= Ceiling ht. \_\_\_\_\_  
B= Highest Point \_\_\_\_\_  
C= Lowest Point \_\_\_\_\_  
D= Reach \_\_\_\_\_

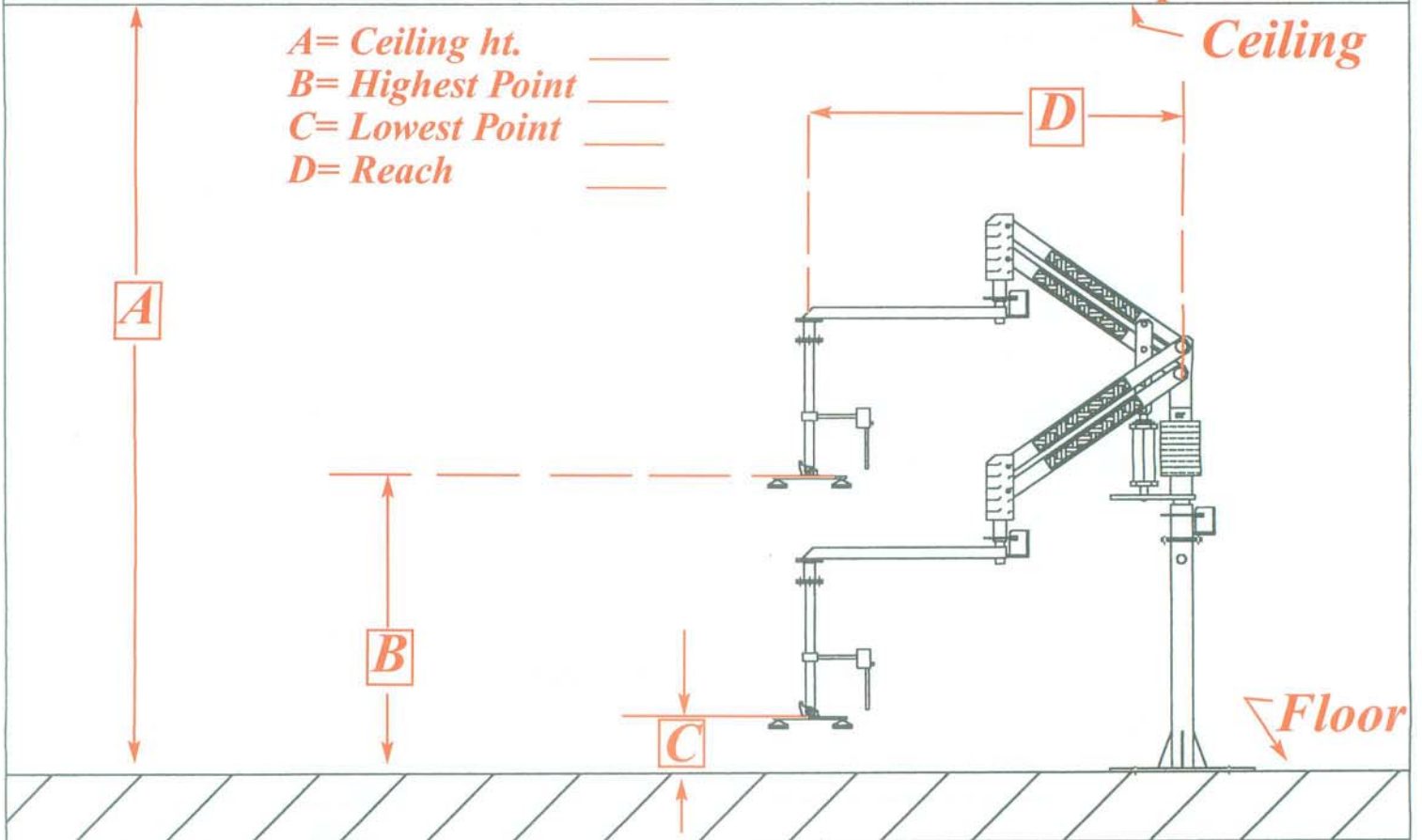

A= Ceiling ht. \_\_\_\_\_  
B= Highest Point \_\_\_\_\_  
C= Lowest Point \_\_\_\_\_  
D= Reach \_\_\_\_\_

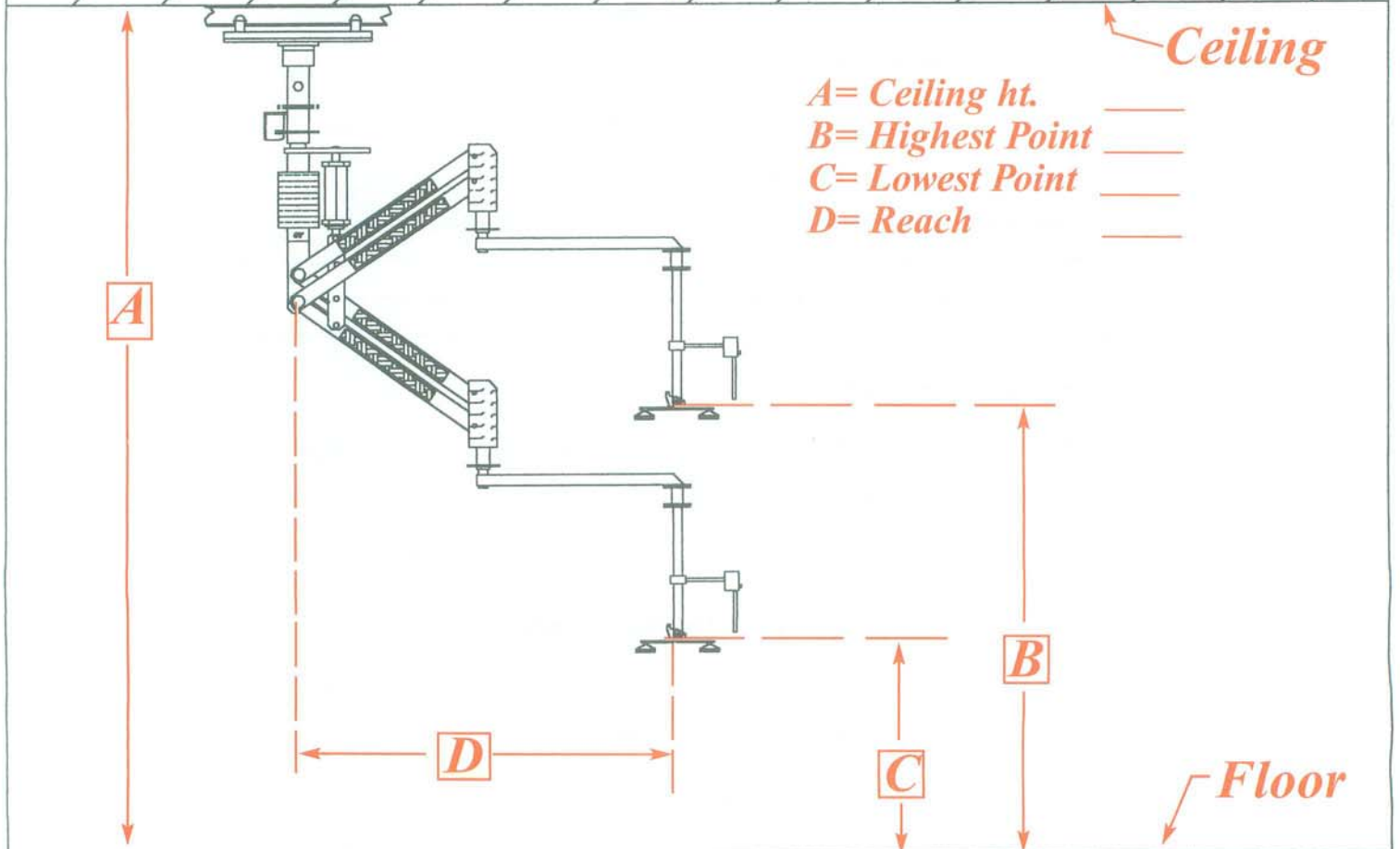

# OVERHEAD MANIPULATOR/Track or Fixed